

# AC-250 Diaphragm Meter

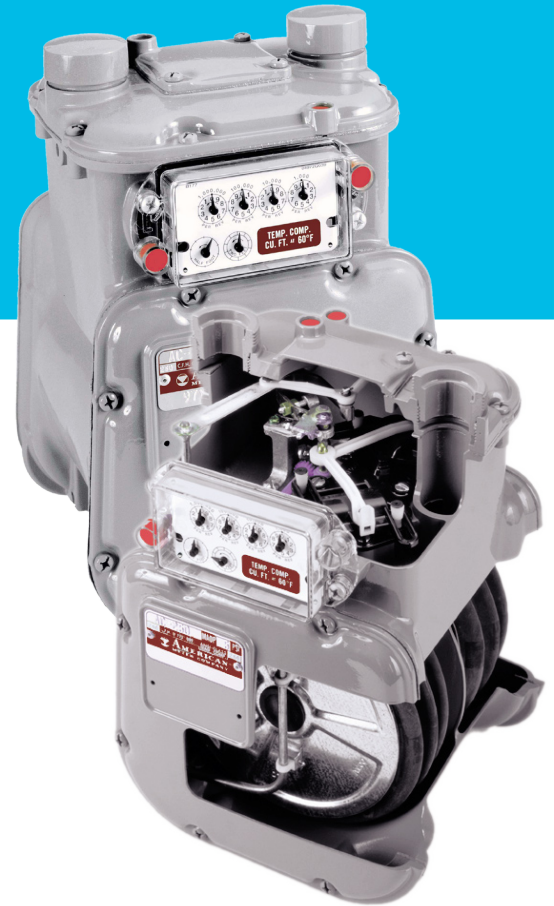

DMC Gas Equipment Limited  
(+852) 2851 2121  
dmcsaleshk@dmc-gas.com.hk  
www.dmc-gas.com.hk



The standard for measuring a variety of hydrocarbon gases at pressures up to 10 PSIG and flow rates up to 250 cubic feet per hour

## Features

- Die-cast aluminum case
- Oil-impregnated, self-lubricating bushings
- Molded, convoluted diaphragms for smooth operation and long life
- Rigid, reinforced flag rods for positive alignment and sustained accuracy
- Graphite-filled phenolic valves to minimize wear
- Long-life, low friction, grommet seals
- Single coat polyester primer with high solids polyurethane top coat
- Security seals that indicate tampering

## Advantages

- Temperature compensation available from -30°F to 140°F (-34°C to 60°C)
- 250 SCFH (7.1 m<sup>3</sup>/h) (0.60 specific gravity gas) at 1/2-inch W.C. differential
- AMR/AMI compatibility
- Meets ANSI B109.1 specifications
- Measurement Canada accredited

## Applications

The Elster American Meter class AC-250 is the industry's most cost-effective gas meter for residential and small commercial applications. It is unequalled for accuracy retention and for life cycle maintenance economies.

## Options

- Regular or Temperature Compensated
- Pointer or odometer index
- 1ft<sup>3</sup>, 2ft<sup>3</sup>, or 0.05m<sup>3</sup> drive
- 10 LT, 20 LT, 30 LT, and other connection sizes
- 5 or 10 PSIG (345 or 690 mbar) Maximum Allowable Operating Pressure (MAOP)
- Pressure compensating indexes
- Standard or UV protected index covers
- Meter bars
- Connection sets
- Remote Volume Pulsers



elster  
American Meter

## AC-250 Diaphragm Meter

Weight = 12 lbs

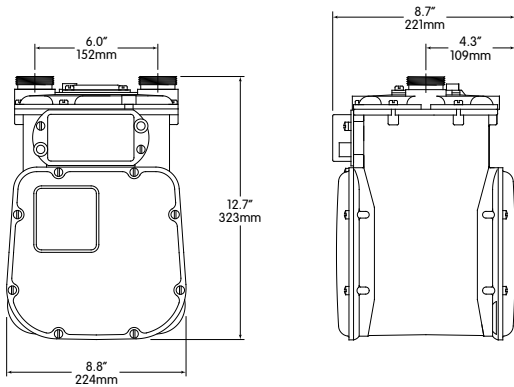

### Capacities (0.60 specific gravity gas)

Line Pressure PSIG (mbar)	Differential Inches W.C. (mbar)	SCFH (m <sup>3</sup> /h)
0.25 (17)	1/2 (1.2)	250 <sup>1,2</sup> (7.1)
1 (69)	2 (5)	583 (16.5)
2 (138)	2 (5)	600 (17.0)
5 (345)	2 (5)	656 (18.8)
10 (690)	2 (5)	742 (21.0)

1 - Propane - 158 SCFH (4.5 m<sup>3</sup>/h)

2 - Butane - 138 SCFH (3.9 m<sup>3</sup>/h)

### AC-250 Proof Curve

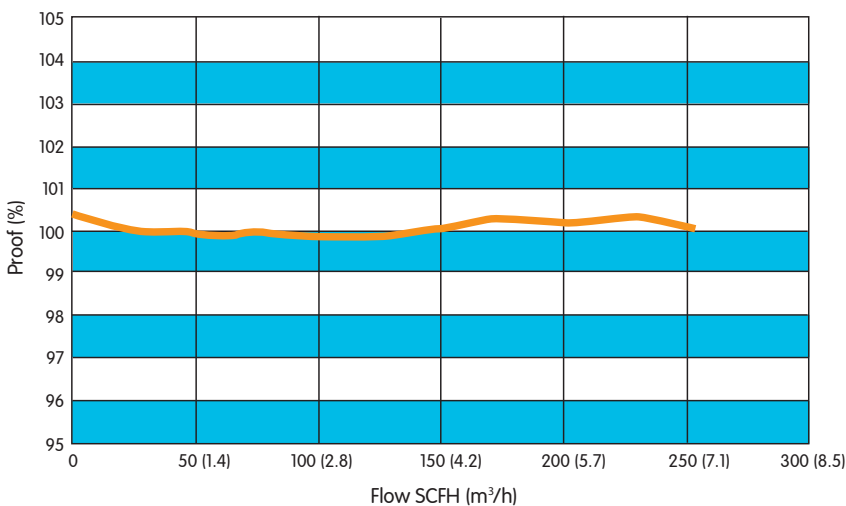

## About Elster Group

A world leader in advanced metering infrastructure, integrated metering, and utilization solutions to the gas, electricity and water industries. Elster's metering and system solutions reflect over 170 years of knowledge and experience in measuring precious resources and energy.

Elster provides solutions and advanced technologies to help utilities more easily, efficiently and reliably obtain and use advanced metering intelligence to improve customer service, enhance operational efficiency, and increase revenues. Elster's AMI solutions enable utilities to cost-effectively generate, deliver, manage, and conserve the life-essential resources of gas, electricity, and water.

Elster has a staff of over 7,500 serving customers globally in North America, Central America, South America, Europe, Asia, Africa and the Middle East.

ISO 9001:2000



Certification No. 006697

**DMC**<sup>®</sup>

DMC Gas Equipment Limited

☎ (+852) 2851 2121

✉ dmcsaleshk@dmc-gas.com.hk

🌐 www.dmc-gas.com.hk

© 2008 Elster American Meter. All right reserved

EAM-DS3535.6-EN-P - November 2008  
Supersedes EAM-DS3535.5-EN-P