

Compact Regulators 302 Series



DMC Gas Equipment Limited
 (+852) 2851 2121
 dmsaleshk@dmc-gas.com.hk
 www.dmc-gas.com.hk

Application

These compact regulators are designed for smaller outdoor grills and fish cookers. It is intended for use on small portable appliances that use 100,000 BTU's/hr. or less. It may not be used on fixed pipe systems per NFPA 58, 1995 edition.

Features

- All metal, die cast construction.
- Molded diaphragms ensure close control of burner pressure.
- Durable valve levers.
- Variety of model configurations and sizes available.
- All POL inlet connections are soft nose.

Materials

Body Die Cast Zinc
 Bonnet Die Cast Zinc
 Springs Steel
 Valve Seat Discs Resilient Rubber
 Diaphragms Molded Synthetic Rubber



302

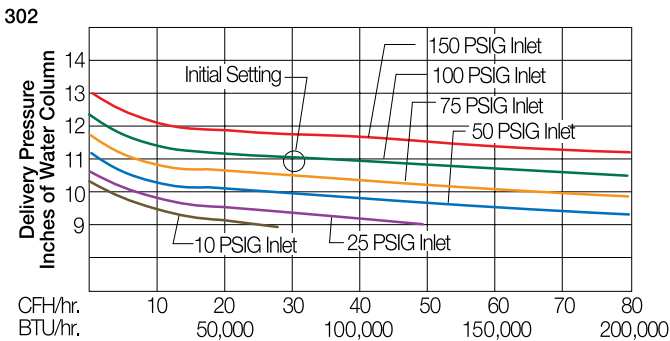
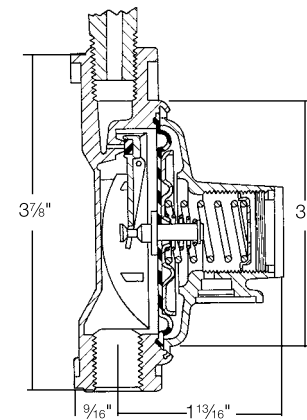

302V

Ordering Information

Part Number	Type	Inlet Connection	Outlet Connection	Orifice Size	Factory Delivery Pressure	Adjustment Range	Bonnet Vent Position	Vapor Capacity BTU/hr. Propane*
302	Single Stage	1/4" F. NPT	3/8" F. NPT	No. 50 Drill	11" w.c. at 100 PSIG inlet	9-13" w.c.	Small Vent Above Inlet	125,000
302V		1/4" F. NPT					Drip Lip Above Inlet	
302V9		1/4" F. NPT					Drip Lip at 9 o'clock	
302V9LS		Soft POL w/o orifice						

Maximum flow is based on 25 PSIG inlet pressure and 9" w.c. delivery pressure.

