

1" Size

APPLICATION

The HPR10 is for pressure reducing applications and has a large diaphragm for accurate regulation of outlet pressure.

PRESSURE

Maximum Inlet Pressure: 21 Bar (305 psig)
Maximum Outlet Pressure: 2.8 Bar (40.6 psig)

CONTROL

A comprehensive range of springs is available, as described overleaf. The outlet pressure can be easily and accurately adjusted by turning the spring adjusting screw.

SIZES

The HPR10 is available in 1" size.

ORIFICE SIZE

The internal orifice is 3/8" diameter.

TEMPERATURE

The HPR10 is suitable for operation in a wide range of temperatures from -20° C to +80° C.

CONNECTIONS

The HPR10 is supplied as standard with a tapered screwed thread to BS21 (ISO 7). Other threads may be available upon request.

SERVICING

The HPR10 has been designed for ease of access, inspection and servicing of all internal components. A standard soft spares kit is available for all sizes.

Reference number SKLHPR10-01

OPERATION

Tight lock-up is ensured by the toggle joint action which applies maximum power as the valve approaches closed position. The toggle mechanism is ruggedly constructed for high pressure service with double diaphragm-stem links and connecting links. The HPR10 is equipped with a diaphragm stem guide, which serves to isolate the diaphragm from the expanding pressure in the regulator body.

The long, straight coil, compression spring provides accurate regulation and is easy to adjust. It may be readily replaced by removing the upper diaphragm chamber.



DIMENSIONS & WEIGHTS

A	B	C	D	E	Weight (Kg)
178	308	38	95	159	7.3

CAPACITIES

Inlet Pressure (Bar)	Outlet Pressure (Bar)	Capacity (scmh)
0.69	0.35	43
2.8	0.35	119
	1.00	119
6.9	2.00	92
	0.35	252
	1.00	252
	2.00	252

Above capacities quoted, SCMH
Propane SG = 1.52 1.0 Bar A

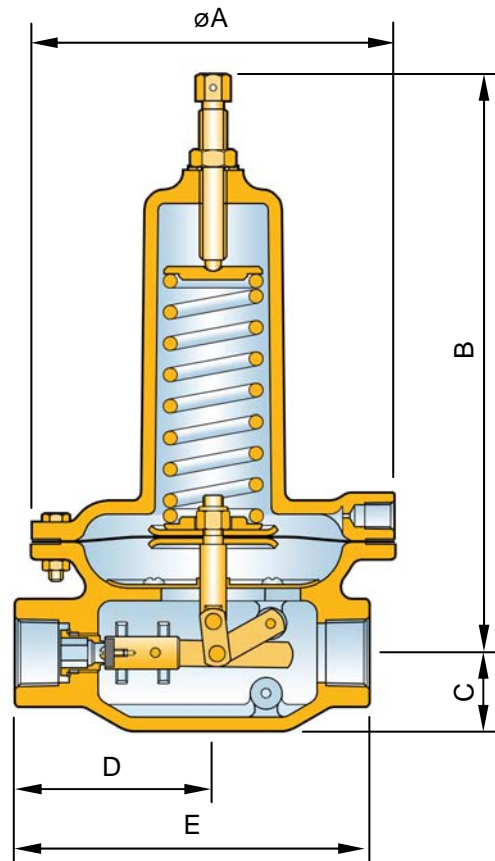

MATERIAL SPECIFICATION

A summary of the material specification for the HPR10 is given for reference. All material has been selected to provide maximum durability and reliability in service.

Components	Specification
Body	S.G. Iron
Main diaphragm	Nylon reinforced Nitrile (Buna N)
Seat disc	Nitrile (Buna N)
Orifice	Brass

QUALITY

Elster Jeavons is committed to a programme of continuous quality enhancement. All equipment designed and manufactured by Jeavons benefits from the company's quality assurance standards which are approved to BS EN ISO 9001 : 1994.

Elster Jeavons has a programme of continuous product development and improvement and in consequence the information in this leaflet may be subject to change or modification without notice.

SPRINGS

All springs are colour coded for ease of identification.

Spring Range		Part Number	Colour Code
Bar	PSIG		
0.17 - 0.34	2.5 - 5.0	I071421P009	Red - Black
0.34 - 1.0	5.0 - 14.5	I071421P011	Green - Black
1.0 - 1.7	14.5 - 24.7	I071421P012	Yellow - Black
1.0 - 2.8	14.5 - 40.6	I071421P014	Blue - Black